

# FELSS

The smarter way of forming.



E-Mobility



Steering

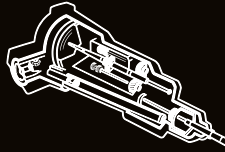

Transmission

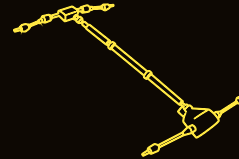

Drive Train

## DRIVE TRAIN

Your progress drives us -  
Light, stable and quiet!

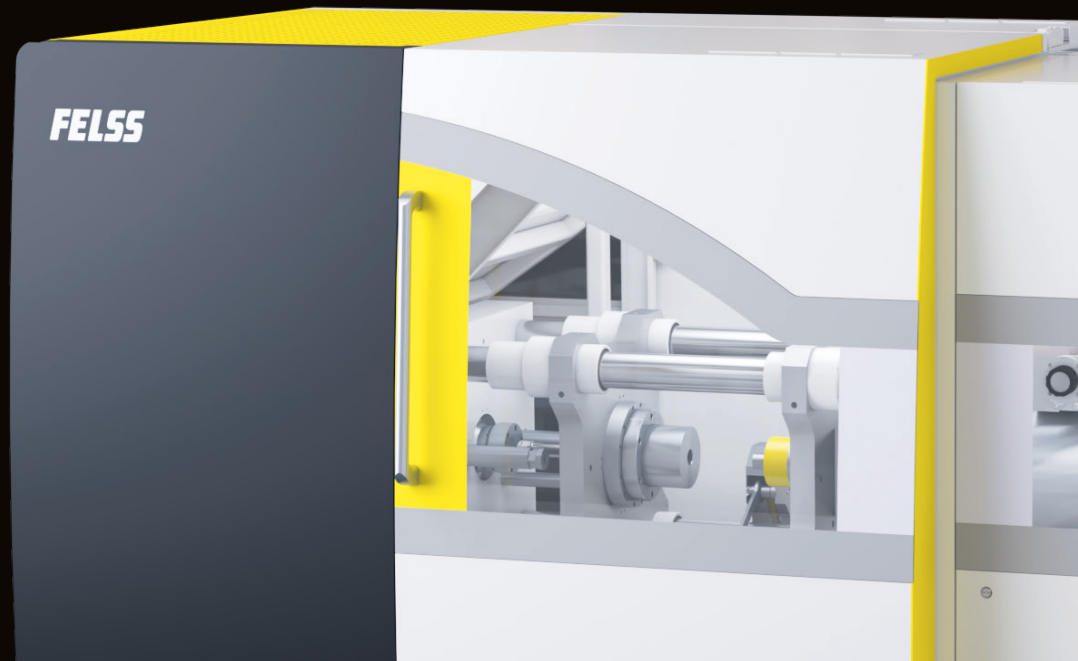

Our benchmarks for your  
“Added Values“:



### LIGHTER

Weight-optimized use of materials  
through intelligent material distribution.



### STRONGER

Improved component performance through  
targeted control of material properties.



### RESOURCE EFFICIENT

Avoidance of waste and complete  
material usage through cold forming.



### FASTER

Reduced production times and optimized  
procedures through innovative processes.



### MORE PRECISE

The greatest precision of complex  
geometries through Felss technologies.

# FELSS

The smarter way of forming.

## THE FELSS GROUP

The Felss Group is your solution provider in the field of cold forming.

As a lightweight construction expert, we develop optimal solutions and processes for our customers - from development to the machine or even to the finished product in component manufacturing.

Worldwide at our locations in Germany, Switzerland, Slovakia, the USA and China, around 800 employees work together with our customers today to meet the challenges of tomorrow.

### FELSS SYSTEMS

Optimal development of machines, manufacturing systems and processes.

### FELSS ROTAFORM

Component manufacturing by specialists, including large-scale production.

[www.felss.com](http://www.felss.com)

FELSS GROUP GMBH  
Dieselstrasse 2  
D-75203 Koenigsbach-Stein

- + Weight savings on the raw material and the finished product.
- + Reduced noise acoustics through lightweight construction (NVH).
- + Very high stiffness due to Felss technology.



Are you interested in forming the future with us?

Then we look forward to your inquiry:

M: [info@felss.com](mailto:info@felss.com)

T: +49 7232 402-0

## DRIVE TRAIN

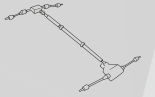

Our lightweight designs create real advantages for your drive.

Weight-optimized drive shaft

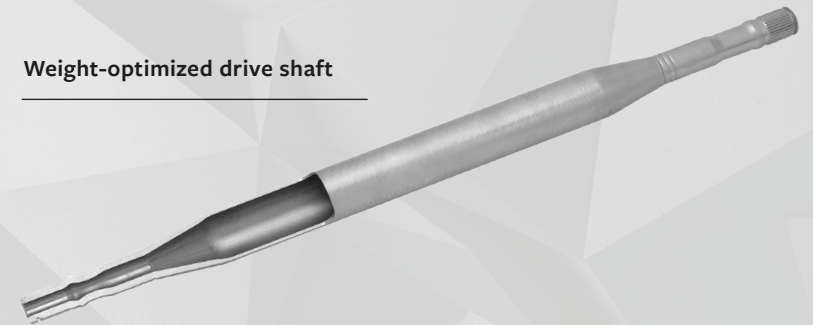

Central shaft



CV joints



# FELSS